

Exploration of Methods for Coupling and Integration of Green Electricity in Aluminium Smelter

Liu Zhiyuan¹ and Liu Chunhao²

1. Chief Engineer

2. Manager

Shenyang Aluminium & Magnesium Engineering & Research Institute, Shenyang, China

Corresponding author: 893934484@qq.com

<https://doi.org/10.71659/icsoba2025-al067>

Abstract

Aluminium electrolysis has a substantial demand for electrical energy. The rational and effective integration of green electricity into aluminium smelters both aligns with policy, and reduces the amount of electricity purchased from the grid, decreases carbon emissions effectively. This approach serves as an effective means to assist the aluminium industry in achieving the dual goals of "carbon peak and carbon neutrality" as well as dual control over energy consumption. Furthermore, many aluminium smelters are located near regions with well-developed or developing green energy industries generation, such as wind power and photovoltaic power generation, which can provide favourable conditions for the application of green electricity. This paper explores methods for the coupling and integration of green electricity in aluminium smelters and proposes optimization suggestions for the current stabilization strategy of the rectification system.

Keywords: Aluminium electrolysis, Green electricity, Coupling and integration, Current stabilization strategy.

1. Introduction: Necessity of Green Power Coupling and Integration in Aluminium Smelters

Since the beginning of the 21st century, China has significantly increased investments and production capacity in renewable energy, driven by the government's heightened emphasis on environmental protection, sustainable development, and international climate commitments. As an energy-intensive sector, the aluminium electrolysis industry requires substantial electricity input, with power consumption being the primary source of carbon emissions during production.

Current data indicate that coal-fired power dominates the electrical supply for aluminium production in China, while renewable sources such as wind and photovoltaic (PV) energy account for a minimal share. Producing one tonne of aluminium emits approximately 1.8 tonnes of CO₂, with the industry's total emissions reaching 438 million tonnes in 2023 – about 5 % of China's net CO₂ emissions. This highlights the sector's immense potential for emission reduction.

Moreover, aluminium production demands consistent and large-scale power supply, particularly in regions with unstable electricity availability or volatile pricing. Integrating wind and solar power has thus become an inevitable trend. Notably, most aluminium plants are located in areas abundant in renewable resources, creating favourable conditions for localized green power consumption. Adopting region-specific renewable energy solutions not only aligns with national decarbonization policies but also reduces reliance on grid electricity, cuts carbon emissions, and supports the industry's dual-carbon and energy efficiency control goals.

However, wind and solar power face challenges such as intermittency, unpredictability, and instability. Without effective integration methods, these issues can lead to power supply

fluctuations and low utilization efficiency in aluminium plants. Therefore, developing tailored green power coupling and consumption strategies which consider the unique power demands of aluminium production and the characteristics of wind/PV generation is essential.

1.1 Power Supply Characteristics of Aluminium Electrolysis

As energy-intensive facilities, aluminium electrolysis plants have consistently ranked among the largest electricity consumers in regional grids [1]. The power load of these plants primarily consists of DC power for electrolytic cells and AC power for auxiliary systems including flue gas purification, compressed air stations, and casting workshops. Notably, DC power consumption accounts for over 95 % of the plant's total electricity demand. For instance, a typical 500 000 t/a aluminium electrolysis plant has total approximately 6.65 TWh power consumption per year, including about 6.4 TWh DC power consumption with electrical costs constituting 40–50 % of total production expenses.

Furthermore, under China's "Dual Carbon" environmental goals (commitment to peak carbon dioxide before 2030 and achieve carbon neutrality by 2060) and industrial adjustments [2], increasingly stringent energy consumption limits per unit product have been imposed on aluminium producers. This has placed high-energy-consumption plants at risk of being phased out as obsolete capacity.

The production process employs molten salt electrolysis, requiring three key materials: alumina, fluoride salts, and carbon anodes. The necessary DC power is supplied by rectifier stations. In electrolysis cells, dissolved alumina undergoes redox reactions with carbon anodes under electrical current to produce molten aluminium. Once electrolytic cells are started and enter normal production, they require a reliable, continuous, and stable DC power supply. If the DC current decreases during production, the cell temperature will drop, leading to reduced output. Prolonged power interruptions may cause a complete shutdown, or even result in solidified aluminium in the cell, damage to the electrolytic cell equipment, and in severe cases, permanent scrapping. Therefore, the DC power supply system for aluminium electrolysis must meet the requirements of Grade I power loads.

The rectifier station is a critical power supply facility in an aluminium smelter, responsible for converting AC power from the external grid into DC power, providing the full DC supply for the electrolytic cells.

1.2 Challenges in Applying Green Power Supply to Aluminium Electrolysis

As previously established, aluminium electrolysis production imposes stringent requirements on power supply stability. A sudden power interruption that cannot be promptly restored may cause severe damage to both production and equipment—particularly to the DC electrolysis system. Such events can significantly reduce electrolytic cell lifespan and even lead to complete system failure. Consequently, both the DC electrolysis system and critical auxiliary production systems must be designed to meet Grade I power load standards.

Photovoltaic (PV) power generation systems, primarily composed of solar panels and inverters, generate electricity that heavily depends on weather conditions such as solar irradiance and ambient temperature. Similarly, wind power systems, consisting of turbines, generators, transmission systems, power converters, and towers, are also subject to natural factors like wind speed and direction. Furthermore, without effective energy dispatch and utilization, significant curtailment of solar and wind power may occur, reducing the overall efficiency of renewable energy usage.

Given these factors, PV and wind power exhibit substantial volatility, unpredictability, and difficulty in maintaining long-term stable supply – characteristics that directly conflict with the stable and reliable power supply required for aluminium electrolysis production. Therefore, resolving the mismatch between intermittent renewable energy and the stable power demands of aluminium smelting, while improving green energy utilization efficiency, has become an urgent challenge.

2. Methods for Coupling and Integration of Green Power in Aluminium Smelter

2.1 Introduction to Direct Green Power DC Coupling Supply to Aluminium Electrolysis

In conventional photovoltaic (PV) power systems, the DC electricity generated by solar panels undergoes inversion (DC → AC) via inverters and step-up transformers before being supplied to the industrial loads. Meanwhile, aluminium smelters rely on rectifier systems (typically 7–10 units per plant) to convert grid AC power back to DC for electrolytic cells. These rectifier systems consist of distribution equipment, on-load tap changers (OLTC), rectifier transformers, rectifier cabinet, DC bus and current stabilizers. This AC-DC-AC-DC double conversion results in energy losses, reducing overall efficiency. To maximize green energy utilization, some smelters are trying to adopt direct DC coupling, where PV-generated DC power bypasses inversion and feeds directly into the electrolysis DC bus. By prioritizing these innovations, smelters can fully harness the potential of green power, ensuring both environmental and economic sustainability.

The photovoltaic (PV) DC Coupling power supply system mainly consists of PV arrays, PV string combiners, boost-type/ buck-type routers (applicable for long-distance power supply), positive and negative bus protection cabinets, and a DC bus integration system. The DC power generated by the PV arrays is collected through the PV string combiners and boosted by the boost-type router. It is transmitted via cable lines to the buck-type router, which adjusts the DC voltage to match the electrolysis bus voltage. The power is subsequently connected to the aluminium plant's DC power supply bus through the positive/negative bus protection cabinets and the DC bus integration system. The structure of the PV DC Coupling power supply system is illustrated in Figure 1.

In addition, the boost-type/ buck-type routers are designed for long-distance PV power transmission. The boost-type router is set in the PV power generation zone, while the buck-type router is set in the electrolytic cells area of the aluminium smelter.

According to the feedback of the electrolytic aluminium producers, the power utilization efficiency of the PV DC coupling power supply system is slightly higher than that of PV AC power supply system. However, due to the limitations of PV generation volatility and current stability control skills, the PV DC coupling power supply ratio is typically capped at 10 % of the series current of the electrolytic cells.

Meanwhile, some electrolytic aluminium producers are exploring methods for direct current (DC) integration of wind power into electrolytic cell power supply systems for consumption. However, there are currently no relevant demonstration project application cases available.

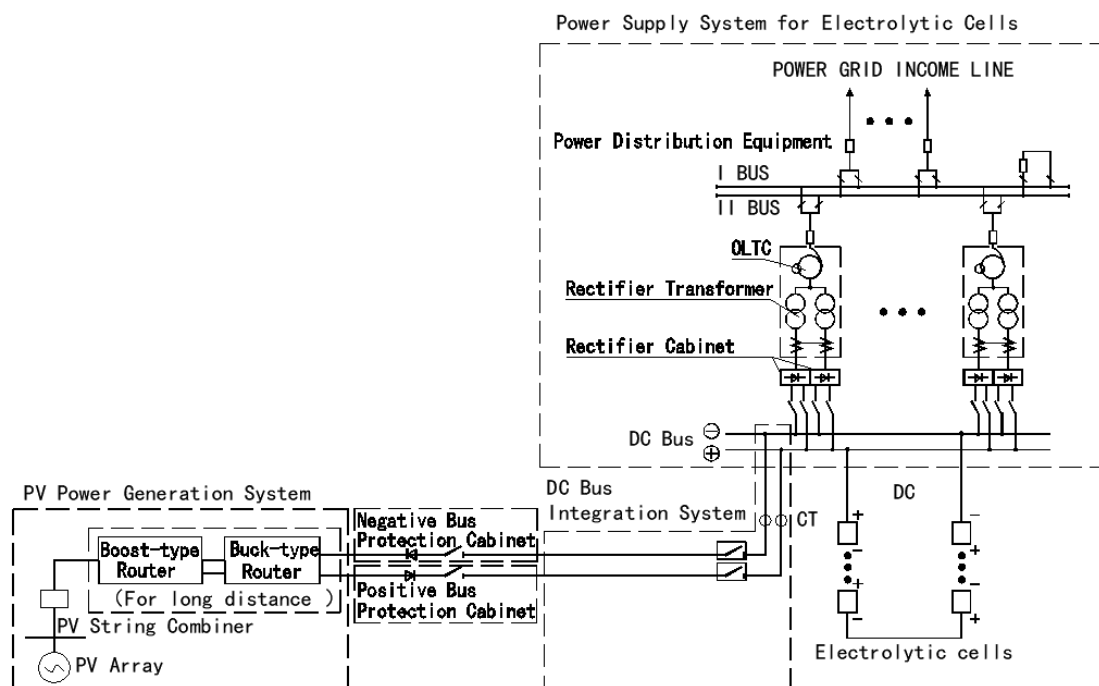

Figure 1. The structure of the PV DC coupling power supply system.

2.2 Introduction to Green Power AC Coupling Supply to Aluminium Electrolysis

The integration of green power into aluminium electrolysis power supply systems primarily involves two AC-coupled approaches: PV power AC coupling supply and wind power AC coupling supply. And PV power AC coupling supply includes distributed PV AC coupling supply which is small-scale, and centralized PV coupling supply. And because the AC-coupled power supply system typically maintains interconnection with the external grid, the integration capacity is much higher than the DC-coupled systems.

2.2.1 Introduction to PV Power AC Coupling Supply to Aluminium Electrolysis

The AC-coupled photovoltaic power supply system primarily consists of PV arrays, inverters, step-up transformers, power collection lines, AC distribution panels and so on. Distributed PV AC coupling supply typically has smaller capacity and utilizes rooftop spaces of workshop buildings within aluminium plants (e. g., electrolysis workshops, anode assembly workshops and so on) for PV modules installation. Through inversion and voltage step-up processes, the generated electricity is supplied to the plant's AC system for power AC-driven equipment (excluding electrolytic cells).

In contrast, centralized PV coupling supply generally features larger capacity. It deploys PV modules on available land both inside and outside the aluminium plant. Through inversion and voltage step-up processes, the power is connected AC grid of the plant. Depending on site-specific conditions, this approach can either supply AC-powered equipment directly, or supply DC power to electrolytic cells via small rectifier units.

2.2.2 Introduction to Wind Power AC Coupling Supply to Aluminium Electrolysis

The wind power AC coupling supply system primarily consists of wind generators, step-up transformers, power collection lines, AC distribution panels and so on. Wind power systems typically feature large-scale generation capacity. Through voltage step-up and other power

conversion processes, the electricity is fed into the aluminium plant's AC grid system. In addition, it can also supply DC power to electrolytic cells via small rectifier units.

3. Suggestions for the Optimization of Rectifier System Current Stabilization Strategy

The current stabilizing control of the rectifier system is a crucial component in ensuring stable DC power supply to electrolytic cells. Maintaining a constant current offers significant benefits, including stabilizing the thermal regime of the cells, improving current efficiency, reducing the workload of electrolysis operators, and minimizing anode effects in the aluminium electrolysis.

Current stabilization in the electrolysis system is closely related to voltage regulation. Therefore, the design of the current stabilization system typically needs to meet the following requirements:

- 1) Ensure the adjustment accuracy of the average current value or A·h value over a certain period to maintain optimal thermal balance and current efficiency in the electrolytic cells.
- 2) Minimize the operation frequency of on-load tap changer (OLTC) to extend their service life and maintenance intervals.
- 3) Comply with automation and intelligent development trends to reduce manual operation workload.

Currently, most aluminium smelters employ automatic current stabilization systems for steady current control. The voltage regulation strategy combines on-load tap changer (OLTC) with the saturable reactor, where the saturable reactor provides smooth "fine-tuning" while the on-load tap changer offers stepwise "coarse adjustment". The current stabilization control system aims to maintain a stable output current from the rectifier. It employs PID current regulation control technology, adjusting the saturable reactor and coordinating with on-load tap changer (OLTC) step adjustments to achieve rapid current stabilization [3]. When an anode effect or other factors cause an increase in voltage and a decrease in potline current, the current stabilization control system executes its regulation strategy as follows:

- 1) If the voltage rise is within the saturable reactor's adjustable range (typically ≤ 70 V): The system sends a command to reduce the control depth of the saturable reactor, thereby adjusting the voltage and stabilizing the output current at the target value.
- 2) However, when the voltage increase exceeds the saturable reactor's adjustable range (typically > 70 V) and persists for an extended period, the current stabilization control system initiates coordinated regulation: The system triggers stepwise voltage compensation by shifting the OLTC tap position. Simultaneously, it optimizes the reactor's control depth (saturation level) to refine the output.

This dual-action control ensures rapid current recovery and maintains stable DC supply to the electrolytic cells, critical for process efficiency and longevity.

To address the volatility of renewable power supply in electrolytic cell DC power systems, the following optimizations are proposed for the rectifier system's current stabilization strategy:

To ensure current stability in the electrolytic cell's DC power supply, the current stabilization system must operate as a closed-loop control system that integrates renewable power (green electricity) inputs. When the DC-coupled renewable power input fluctuates, the current stabilization system dynamically adjusts the rectifier unit's output based on real-time measurements from the total DC current sensor, thereby maintaining a ripple-free constant DC output current.

As an interlocking condition, the current stabilization system initiates the aforementioned control strategy upon detecting the photovoltaic (PV) system's operational status. Based on the PV

system's injected current magnitude, the system selects between master-slave coordinated control (total adjustment) or distributed independent control (partial adjustment) as follows:

- a) Master-slave coordinated control: The photovoltaic (PV) system's injected current is subtracted from the current stabilization system's setpoint value.
- b) Distributed independent control: The PV system's output current is divided by the number of operational rectifier units to obtain the deduction value per rectifier, which is then subtracted from each unit's current setpoint value.

Furthermore, significant variations exist in PV output current volatility due to regional climate differences and photovoltaic system configurations. When PV DC-coupled current fluctuations exceed $\pm 5\%$ of the aluminium electrolysis potline current, the following measures are recommended to enhance current stabilization performance:

- 1) Coordinated control strategy upgrade: Implement constant-power voltage regulation for current stabilization [3].
- 2) Utilize thyristor-based rectification elements to achieve superior dynamic response and current stabilization performance.
- 3) Integrate flexible aluminium electrolysis production technology by deeply coupling the PV DC power supply system with the electrolytic cell's flexible production process to enhance energy efficiency.

4. Conclusions

Under China's "Dual Carbon" goals (commitment to peak carbon dioxide before 2030 and achieve carbon neutrality by 2060), integrating green electricity into aluminium smelters and coupling it with flexible consumption not only aligns with national decarbonization directives but also significantly reduces grid power purchases and optimizes the plant's specific energy consumption metrics. Globally, an increasing number of aluminium plants have successfully integrated renewable energy (primarily photovoltaic and wind power) into their production processes, achieving significant operational and environmental benefits [4–5]. For example, the aluminium smelter in Huolinhe, Inner Mongolia has successfully implemented a wind-PV-energy storage hybrid power supply system to provide electricity for its production. Aluminium smelters in Yangzhonghai Yunnan, Qingtongxia Ningxia and other regions have successfully implemented DC-coupled photovoltaic power supply systems for their production. However, the inherent intermittency and variability of certain renewable energy sources (such as wind and solar PV generation) necessitate the implementation of flexible power supply strategies and the development of the ways of coordinated current stabilization specifically designed to accommodate the characteristics of green electricity. Through optimized control parameters, enhanced regulation response speed, intelligent energy dispatch, and strategic deployment of customer-side energy storage and so on, it mitigates production instability in aluminium electrolysis caused by power fluctuations, improves green electricity utilization efficiency, achieves "Dual Carbon" goals [6].

5. References

1. Liu Y., Research on energy-saving and emission-reduction measures for electrical facilities in aluminium smelters and alumina refineries under the 'dual carbon' goals, *Light Metals* 2023, 50–53. (in Chinese).
2. Standardization Administration of China. GB 21346-2022, Energy consumption limits per unit product of aluminium electrolysis and alumina, *Beijing: Standards Press of China*, 2022. (in Chinese)

3. *Power Design of Silicon Rectifier Stations*, Power Department of Shenyang Aluminium & Magnesium Engineering & Research Institute. Beijing: Metallurgical Industry Press, 1983. (in Chinese)
4. Y. Zhang and H. Chen, Thoughts and choices on the development path of Yunnan's green aluminium industry under the 'dual carbon' background, *Light Metals* 2023, 1–2, 13. (in Chinese)
5. T. Chu et al., Capacity optimization design of wind-solar hybrid captive power plants for aluminium electrolysis, *Light Metals* 2022, 58–62. (in Chinese).
6. Du, X., Xie, W. and Wang, S., Research on carbon peak and neutrality pathways for China's aluminium industry, *Energy Saving of Nonferrous Metallurgy*, 2021(37): 1–4. (in Chinese).

